

# Outpatient LED

Floor Stand, Wall, Single and Double Ceiling

Installation Instructions

5000557 A01



**PHILIPS**  
**burton**

## **Introduction**

Congratulations on your purchase of a Philips Burton Outpatient LED medical examination light!

The Outpatient LED examination light is designed to provide the professional health care market with superior performance, reliability and value. Outpatient LED is engineered with advanced electrical, optical and mechanical components intended to offer you and your patient a more comfortable working environment, superior light quality for accurate color and pigment rendition, and unsurpassed value.

## **Outpatient LED—General Information**

Outpatient LED is an easy to use medical lighting fixture that can be utilized in a variety of spaces. It is offered in four different mounting configurations for your application.

For mobility, Outpatient LED is offered on a sleek mobile floor stand that can be plugged into any 120VAC three prong outlet used in the US and Canada. Locking casters provided help prevent movement of the floor stand while set in position. The upright handle guides in moving the light and dually functions as a convenient cord wrap.

For lower ceiling heights or crowded ceiling space, the Outpatient LED is offered in a fixed wall mount.

For dedicated rooms, fixed single and dual ceiling mounting options are available. Spring arms provide 360 degree rotation for flexibility with adjustment of light head to the correct and desired position for your application.

A convenient removable central handle is used to align and adjust the light head to the correct position and can be autoclaved. In addition, disposable covers can be mounted over the handle to reduce cleaning time and provide for a more sanitary environment.

Main power to the fixture is controlled from a wall switch for the wall, single and dual ceiling mounting options. The floor stand model is offered with a footswitch to control the main power coming into the fixture. A user replaceable fuse is provided for additional protection from incoming line power fluctuations and transients.

The Outpatient LED is manufactured and assembled in the USA. It has been tested by a Nationally Recognized Testing Laboratory (NRTL) for safe operation in the US and Canada. Testing of the Outpatient LED meets the medical light standards of AAMI ES60601-1 3rd ed., IEC60601-1-2 and IEC60601-2-41.

**DO NOT DISCARD!**

**PRODUCT MODELS COVERED IN THIS INSTALLATION INSTRUCTION**

<b>BASE MODEL</b>	<b>MOUNT</b>	<b>AREA</b>
<b>OPLED</b>	<b>W</b> (wall) <b>FL</b> (floor) <b>SC</b> (single ceiling) <b>DC</b> (double ceiling)	<i>BLANK</i> <i>(United States and Canada, 120V)</i>

**UNPACKING NOTES**

Prior to unpacking product cartons, perform a check on packing slip and purchase order to make sure all cartons are accounted for from the carrier. If there are packages missing, make note and report to carrier of missing packages.

If there is a back order on certain parts, items indicated in the column headed "Back Order" are not included in the shipment and will follow later.

Shipping damage should be reported to the carrier.

## Table of Contents

1.0 Safety Notes .....	5
1.1 User Profiles .....	5
1.2 Safety Symbols.....	6
1.3 Safety Precautions.....	6
1.4 Safety Warnings.....	7
2.0 OPLEDFL Assembly .....	8-19
3.0 OPLEDW Assembly .....	19-28
4.0 OPLED SC Assembly.....	29-38
5.0 OPLED DC Assembly.....	39-49
6.0 Additional Notes.....	50
7.0 Trouble Shooting.....	51-52
8.0 Technical Data .....	53-56
10.0 Warranty .....	57
Philips Burton Information .....	58

## 1.0 SAFETY NOTE

Philips Burton firmly recommends that all instructions, precautions and warnings provided in this Installation Instruction be followed to avoid the potential risk of injury. Here is a list of safety tips to follow:

- Philips Burton fixtures should be installed and assembled only by certified installers.
- At any time during installation or assembly should an instruction be unclear, STOP and contact Philips Burton for clarification.
- Proper training on the use and safety precaution of the product is highly recommended to all users or operators of this device.
- If problems are encountered that have not been addressed in these installation instructions, please contact Philips Burton for clarification.
- These installation instructions only apply to the product listed here and should not be used for any other products.
- Modifications are never to be made for any reason. This is to ensure safety for all persons involved and to maintain warranty.

## 1.1 USER PROFILES

### Medical staff

All persons with medical training who work in the field for which they were trained.

### Cleaning staff

All persons familiar with national and workplace hygiene requirements.









### Electricians

All persons with training in electronics and electrical technology who are familiar with the relevant standards and regulations.



### Certified installers

Persons qualified by training, experience and knowledge of the regulations to install and remove the equipment.













## 1.2 SAFETY SYMBOLS

SYMBOL	MEANING	DESCRIPTION
	WARNING	Disregarding this instruction can present the risk of a serious or fatal injury.
	CAUTION	Disregarding this instruction can result in medium to minor injury and damage to property.
	ELECTRIC SHOCK	An electric shock warning symbol. Non-compliance with this symbol may result in injuries due to electric shock.
	NOTE	Mandatory reading information.
	GND	Protective ground connection
	ON/OFF	On / Off (power connection/disconnection to the mains)
	AC	Alternating current
	HOT SURFACE	"Hot Surfaces" Symbol

## 1.3 SAFETY PRECAUTIONS

SYMBOL	MEANING	DESCRIPTION
	CAUTION	This is a medical light. Do not use this product outside its intended application.
	CAUTION	When in doubt, contact your local technical support representative or Philips Burton for help.
	CAUTION	Use a mild detergent or other non-alcohol based cleaning products to wipe down your fixture after use.

#### 1.4 SAFETY WARNINGS

SYMBOL	MEANING	DESCRIPTION
	WARNING	Fixture must be installed by certified installers. Failure to use a certified installer could potentially result in injury.
	WARNING	Do not use the fixture if it does not appear to work properly. Alert your maintenance department or Philips Burton of observed deficiencies and have them corrected before continuing use of the light.
	WARNING	To maximize the product lifetime, follow maintenance procedures in the Instructions for Use (IFU). Failure to do so can result in decreased lifetime.
	WARNING	Do not look directly into the light source.
	WARNING	Suitable for dry locations only
	WARNING	Do not use the fixture head handle as a means to move the fixture. When transporting or moving the floor model, the arm must be in the retracted position and control of the fixture must be maintained at all times by the upright handle. Failure to do so could result in the tipping of the fixture.
	WARNING	Do not attempt to service the fixture when power is applied to the fixture. Fully disconnect the fixture from all incoming line power before servicing.
	WARNING	Outpatient LED is designed for use with only Burton approved arm systems. Use with any other arms systems could pose risk of injury and void any warranty.
	WARNING	Do not bump or bounce fixture arm during operation. Excessive mechanical shock can cause premature failure or operation anomalies.
	WARNING	Do not force arm(s) to swing past its built in stop. Failure to do so can result in mechanical and/or electrical malfunction resulting in possible injury and void of product warranty.
	WARNING	The wall switch must be installed for wall, single and double ceiling mounting options. Failure to install the wall switch can result in premature product failure and void any warranty.
	WARNING	The wall switch must be switched off after every use. Failure to abide by this guideline can result in the premature failure of fixture.
	WARNING	This is not a toy. Proper use of product will prevent risk of injury, premature failure and void of warranty.

## 2.0 OPLEDFL ASSEMBLY



### WARNING

Fixture must be installed by certified installers. Failure to use a certified installer could potentially result in injury.



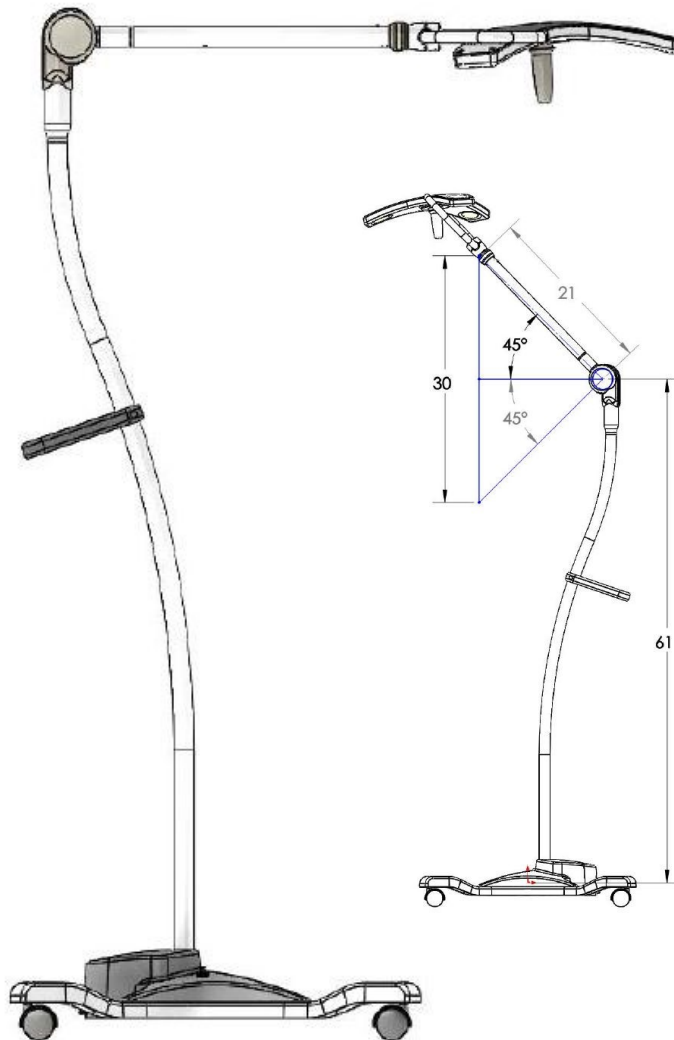

**Prior to start, make sure all components are available for assembly and installation.**

### Assembled Fixture





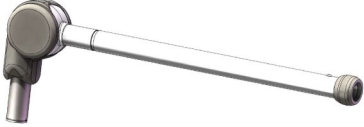

## 2.0 OPLEDFL ASSEMBLY CONTINUED

	<b>WARNING</b>	Fixture must be installed by certified installers. Failure to use a certified installer could potentially result in injury.	
<b>Component Picture</b>		<b>Description</b>	<b>Part Number</b>
		Floor stand base with 4 locking casters	6000314
		Floor stand upright with handle	6000314
		OPLED Head, handle and Yoke Assembly	6000263
		OPLED FL Spring Arm	6000314

## 2.1 Floor Base Assembly

	WARNING	Fixture must be installed by certified installers. Failure to use a certified installer could potentially result in injury.
	ELECTRICAL SHOCK	Disconnect power cord and remove all fuses prior to assembly.

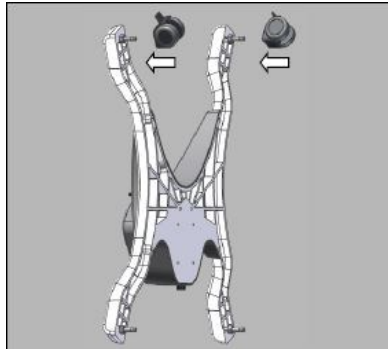

2.1.0  
Install the brake casters onto the front legs of the base. Press them firmly until they snap in place.

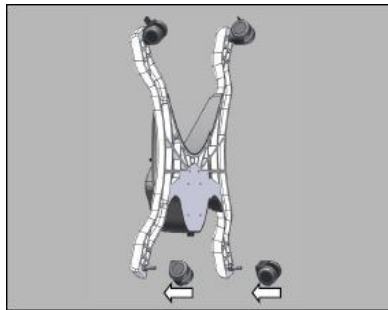

2.1.1  
Install the remaining brake casters onto the rear legs of the base. Press them on firmly until they snap into place.

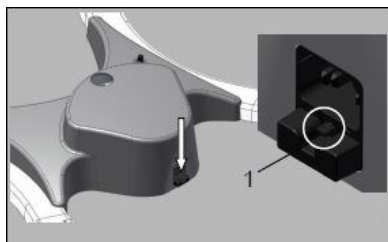

2.1.2  
Remove the fuse holder by pushing on the tab (1) and pulling outward.

## 2.1 OPLEDFL ASSEMBLY CONTINUED

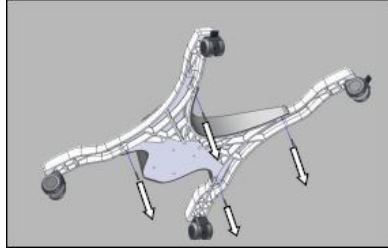

2.1.3  
Remove the four M4 allen screws shown from the bottom of the base.

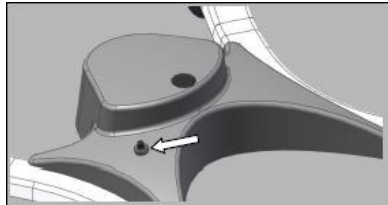

2.1.4  
Unscrew and remove switch nut.

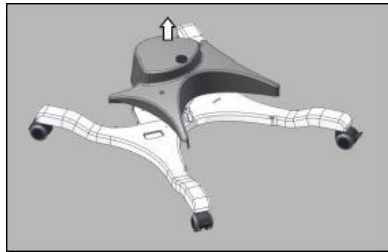

2.1.5  
Carefully remove the cover and set aside.



2.1.6  
Take the post and remove the M3 allen screw (1).



2.1.7  
Slide the cover onto the post and reinstall the M3 allen screw.



2.1.8  
Pull approximately 1" of cable through the oval hole at the bottom of the post.

## 2.1 OPLEDFL ASSEMBLY CONTINUED

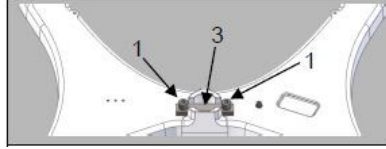

2.1.9  
Remove the M8 allen screws and lock washers (1), and the attachment bar (3) from the base.

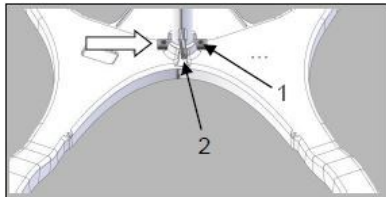

2.1.10  
Insert the post into the base, then slide the attachment bar (1) into place. Ensure the connector is facing the front of the base as shown (2).

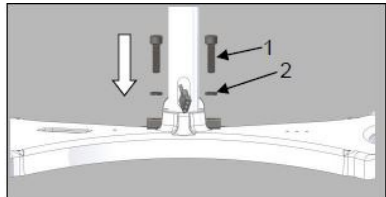

2.1.11  
Reinstall the two M8 allen screws (1) and lock washers (2). Ensure they are tightened securely.

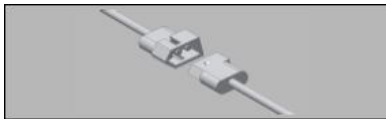

2.1.12  
Join the post connector to the transformer connector.

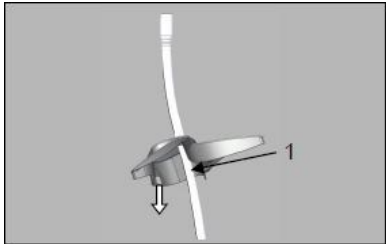

2.1.13  
Remove the M8 allen screw (1) and lower the cover onto the base. Reinstall the M3 allen screw.

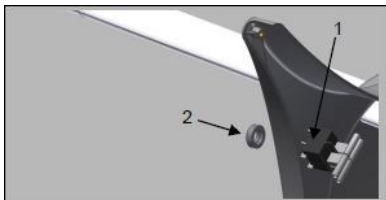

2.1.14  
Lift the cover slightly, and fit the switch (1) in place. Secure the switch with the switch nut (2).

## 2.1 OPLEDFL ASSEMBLY CONTINUED

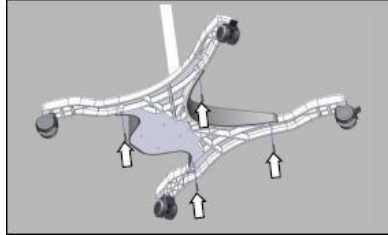

2.1.15  
Position the cover on the base and re-install the four M4 allen screws.

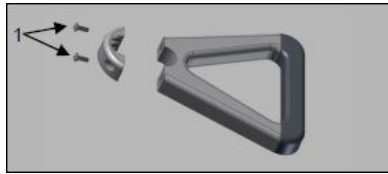

2.1.16  
Remove the two screws (1) from the handle.

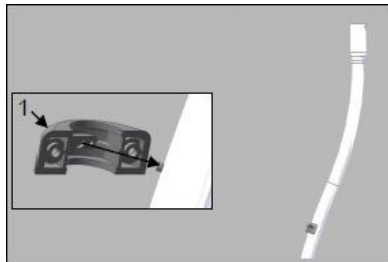

2.1.17  
Position the small part of the handle on the post. Ensure the curved portion (1) faces up, and the hole is placed over the M3 allen screw.

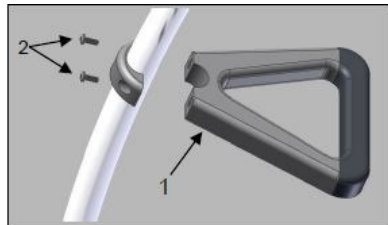

2.1.18  
Install the large part of the handle (1) using the two screws (2) removed earlier.

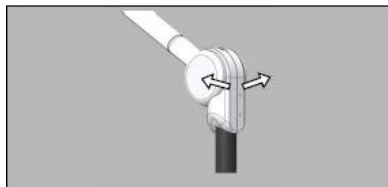

2.1.19  
Take the spring-balanced arm and gently pry the two halves of the cover apart.

## 2.1 OPLEDFL ASSEMBLY CONTINUED

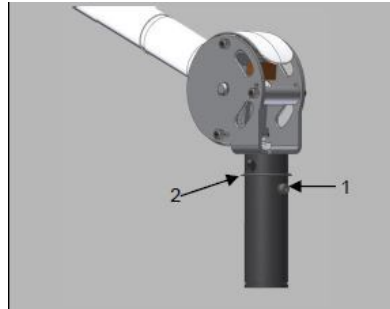

2.1.20  
Remove the M4 allen screw and lock washer (1). Ensure the washer (2) stays in position.

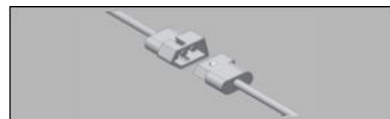

2.1.21  
Join the arm connector to the connector in the top of the post.

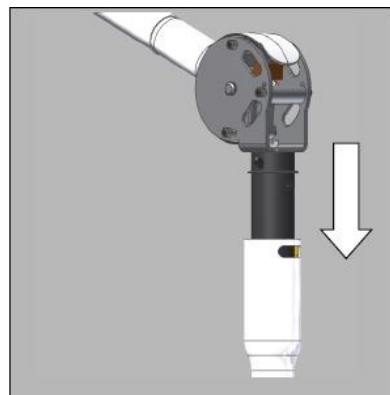

2.1.22  
Push the connector into the post and slide arm into the top of the post.

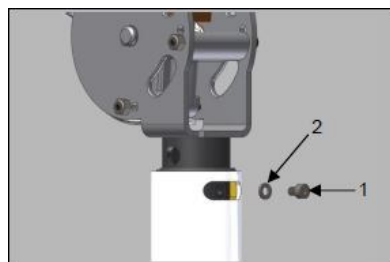

2.1.23  
Line up the hole in the spring arm with the slot in the post, then install the M4 allen screw (1) and lock washer (2).

## 2.1 OPLEDFL ASSEMBLY CONTINUED

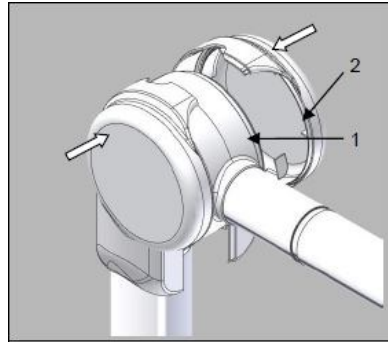

2.1.24  
Reinstall the covers halves one at a time. Ensure the flap (1) is positioned in the groove of each cover (2).

	<p><b>WARNING</b></p>	<p>Fixture must be installed by certified installers. Failure to use a certified installer could potentially result in injury.</p>
	<p><b>WARNING</b></p>	<p>The spring arm is under a high spring load. If the cantilever is lowered without a device installed, it MUST be held firmly. If it is released it will spring up, possibly causing serious injury. Only remove the light head if the spring arm is in the upper position, or held securely in a lowered position by a second person.</p>
	<p><b>ELECTRICAL SHOCK</b></p>	<p>Disconnect power cord and remove all fuses prior to assembly.</p>

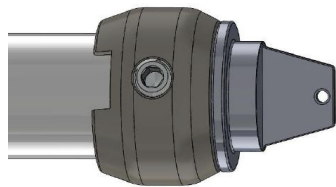

2.1.25  
Locate spring arm collar, set screw and plug at end of spring arm

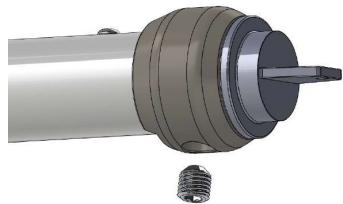

2.1.26  
Remove the set screw from collar.

## 2.1 OPLEDFL ASSEMBLY CONTINUED

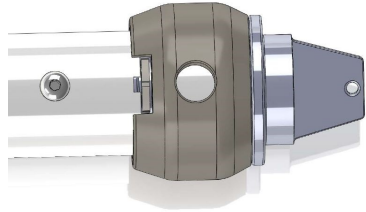

2.1.27  
Rotate collar 180 degrees until the collar notch exposes the locking clip on the spring arm.

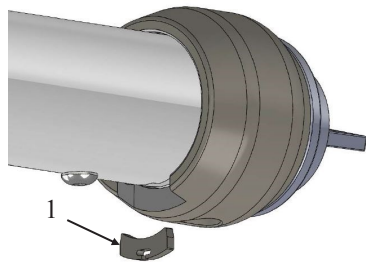

2.1.28  
Remove the locking clip (1) from spring arm.

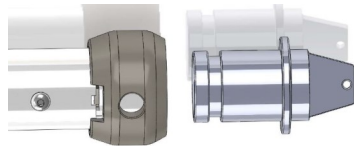

2.1.29  
Once the locking clip is removed, the plug on the end of the spring arm can now be removed. Leave collar on arm and collar notch aligned to locking clip.



2.1.30  
Remove OPLED Head and Yoke assembly from carton.

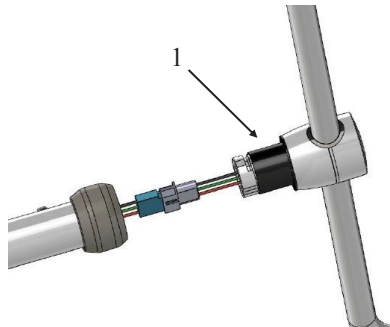

2.1.31  
Connect the 3 position connector in the spring arm to the 3 position connector on the OPLED Head and Yoke assembly. Make sure there is a positive latch on the connector once connected. Lube bushing (1).



## 2.1 OPLEDFL ASSEMBLY CONTINUED

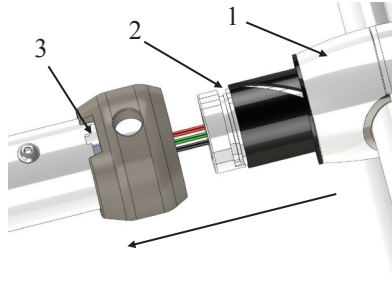

2.1.32

Gently push connector back inside arm and yoke adapter (1). Align yoke adapter to arm and gently insert into arm. Make sure the yoke adapter groove (2) is inline with the arm locking clip slot (3).

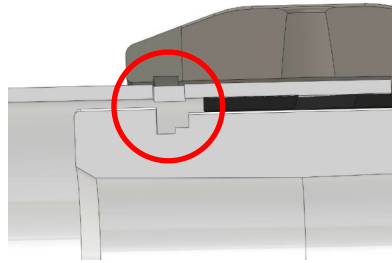

2.1.33

Cut-out close up view of how the yoke adapter groove aligns to arm locking clip slot when mated.



2.1.33

Once aligned, insert locking clip into arm slot as shown. The locking clip should sit flush with the arm circumference allowing the collar to rotate about the arm without obstructing the locking clip.

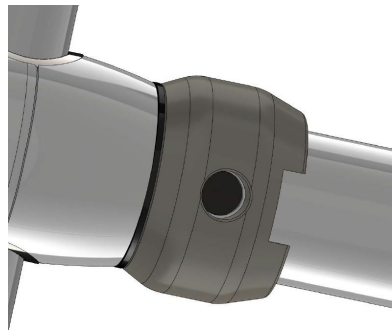

2.1.34

Rotate the collar 180 degrees from the locking clip. Align the hole in the arm to the set screw hole in the collar.

## 2.1 OPLEDFL ASSEMBLY CONTINUED

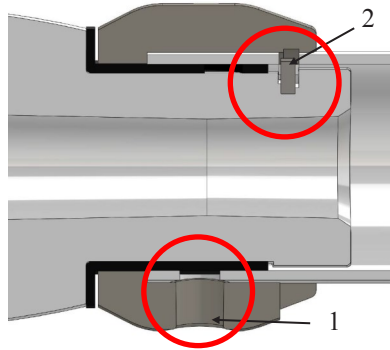

2.1.35  
Cut-out close up view of how the set screw hole (1) is rotated 180 from the locking clip (2) and aligned to the arm hole.

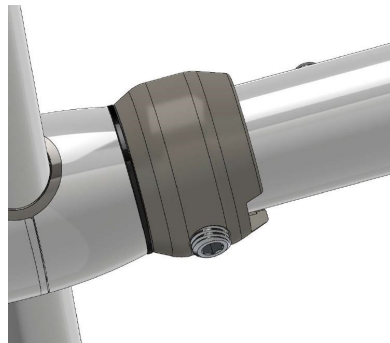

2.1.36  
Insert set screw. Turn set screw until a little resistance is felt. Try and rotate the collar back and forth against the arm. The collar should not rotate freely. If the collar rotates, reposition the set screw hole to the arm hole and try again. Once collar does not rotate, give set screw another 1/2 turn. DO NOT OVER TIGHTEN THE SET SCREW.

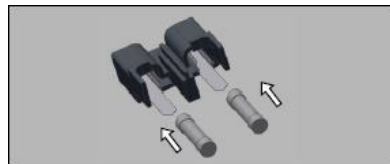

2.1.37  
Install the two fuses (4000118) into the fuse holder.



2.1.38  
Install the fuse holder with fuses back into the base.

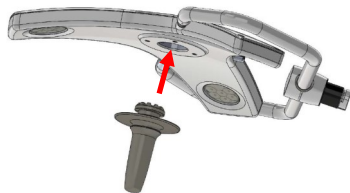

2.1.39  
Insert fixture handle to the light head, resistance may be needed behind the head to insert the handle. You will hear a snap when fully engaged. Test by gently pulling on handle away from head.

## 2.1 OPLEDFL ASSEMBLY CONTINUED

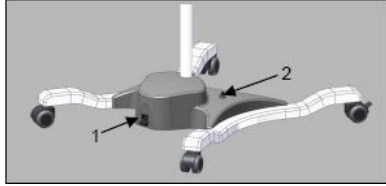

2.1.40  
Insert power cord into (1). Test fixture by pressing on (2).

## 3.0 OPLEDW ASSEMBLY



### WARNING

Fixture must be installed by certified installers. Failure to use a certified installer could potentially result in injury.

**Prior to start, make sure all components are available for assembly and installation.**

### Assembled Fixture

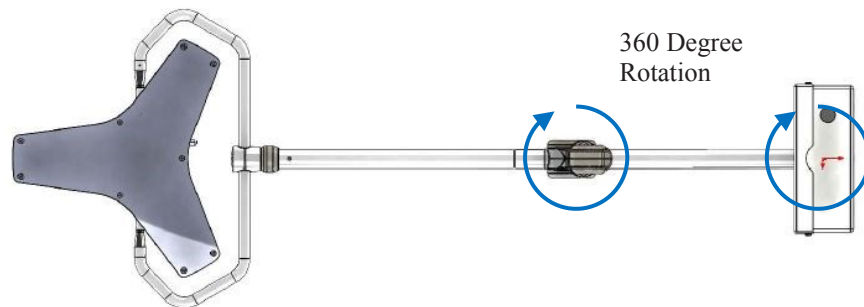
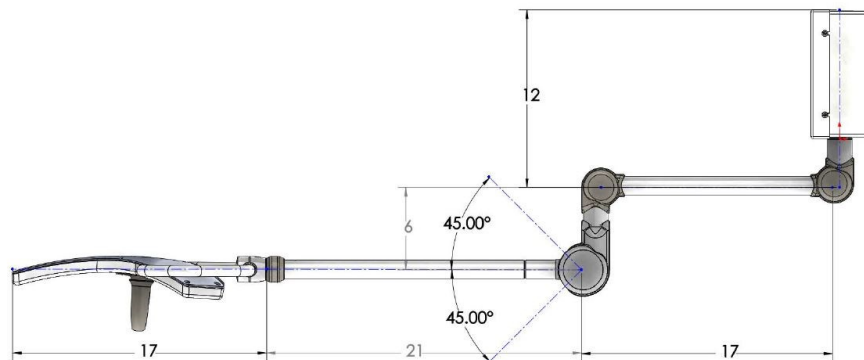



### 3.0 OPLEDW ASSEMBLY CONTINUED

#### 3.1 Wall Mount Assembly

	<b>WARNING</b>	Fixture must be installed by certified installers. Failure to use a certified installer could potentially result in injury.	
<b>Component Picture</b>	<b>Description</b>	<b>Part Number</b>	
	Wall Mount Power Supply Box	6000309	
	OPLED Extension Arm	4000288	
	OPLED Head and Yoke Assembly	6000263	
	OPLED Wall Switch 2A Fuse	6000134-1	

### 3.1 OPLEDW ASSEMBLY CONTINUED

	WARNING	Fixture must be installed by certified installers. Failure to use a certified installer could potentially result in injury.
	ELECTRICAL SHOCK	Disconnect power cord and remove all fuses prior to assembly.
	WARNING	It is the responsibility of the user to properly install all devices.



#### 3.1.0

Layout your room and pick a location for the light control switch. Electrical connections between the mains line to the fixture will run thru and are controlled by this switch. Locate this switch in a location that can be easily accessed by the user. The wall switch requires a j-box provided by installer.



#### 3.1.1

Pick a mounting location for your wall mount box. Make sure you have properly measured the height for your application. Wall mount fixture dimension and travel is at the beginning of section 3.0. Spring arm travel is on Page 8. Weight of the fixture can be found in Section 8.

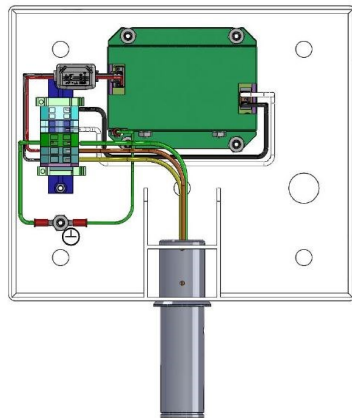



#### 3.1.3

Remove the lid by unscrewing the slot head screws on the side of the box.

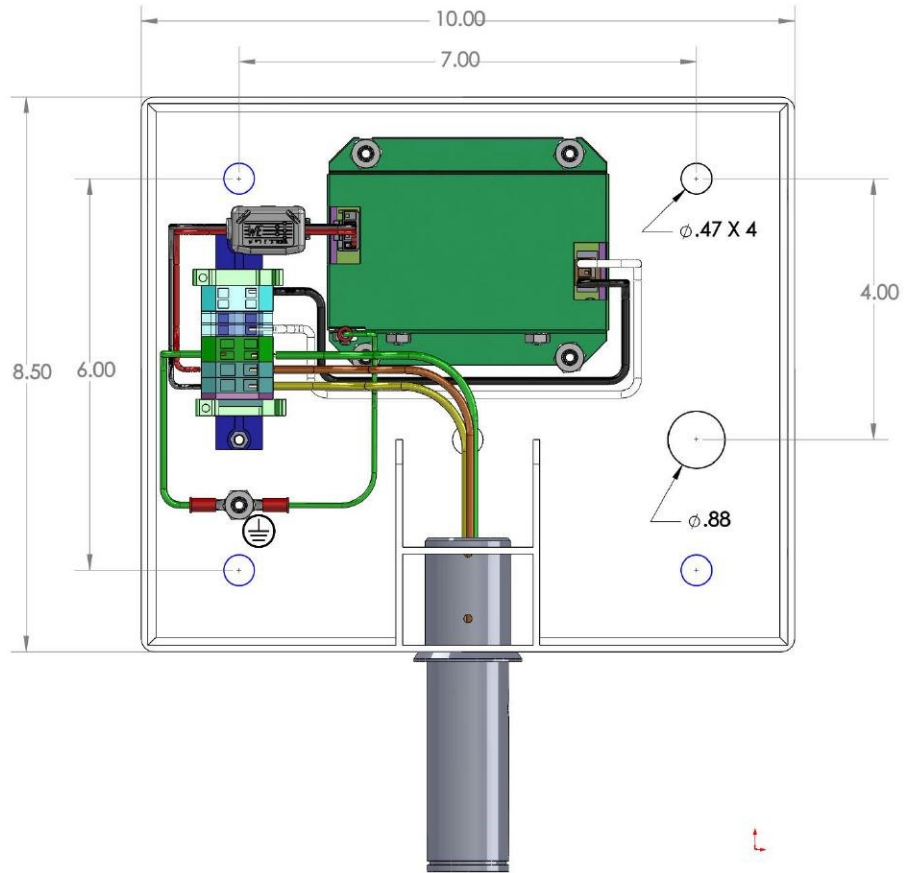
### 3.1 OPLEDW ASSEMBLY CONTINUED



	<p><b>WARNING</b></p>	<p>Fixture must be installed by certified installers. Failure to use a certified installer could potentially result in injury. It is the responsibility of the installer to provide the mechanical structure to support the fixture and its operation.</p>
	<p><b>WARNING</b></p>	<p>Make sure the arm mounting shaft is installed level or your arm could see unnecessary drifting.</p>

#### 3.1.4

Mounting hardware is provided for convenience. It is the installer's responsibility to provide the mechanical structure to support this fixture installation.

### 3.1 OPLEDW ASSEMBLY CONTINUED

	<p><b>ELECTRICAL SHOCK</b></p>	<p>Disconnect all power and remove all fuses prior to assembly.</p>
---	--------------------------------	---

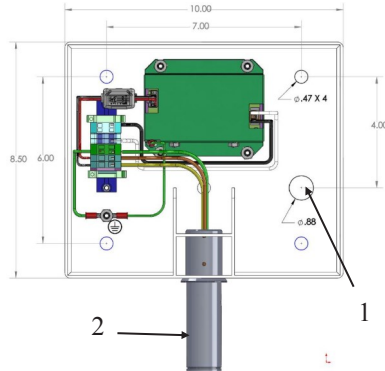

**3.1.5**  
Run your electrical conduit from the wall switch thru to the back side 0.875” hole provide (1) in the wall mount box. Secure your electrical ground to the GND terminal provided. 16-18AWG wire may be used. Add lube to stem (2).

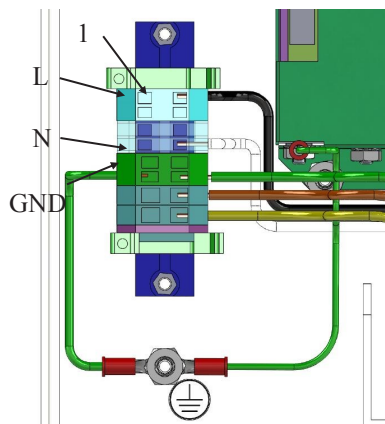

**3.1.6**  
Strip your wire lengths to be about 5/8”. Depress the spring contact (1) on the terminal block by pressing it down and inserting your wire into the side of the terminal block. Connect the Line and Neutral side to the correct locations. Connect the ground to the GND on the terminal block. For detail view see next page.

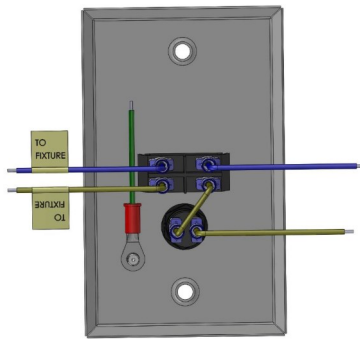

**3.1.7**  
Connect the wires from the wall box to the wall switch. Line side is connected to the brown lead with the label “To Fixture” of the wall switch. Neutral is connected to the blue lead with the label “to Fixture” of the wall switch. Ground on the wall switch is connected to safety ground. The brown (Line) and blue (Neutral) without the label is connected to the building power. Make sure all power is disabled prior to connecting wires.

### 3.1 OPLEDW ASSEMBLY CONTINUED

	<b>ELECTRICAL SHOCK</b>	Disconnect all power and remove all fuses prior to assembly.
---	-------------------------	--

#### DETAILED VIEW OF 3.1.6

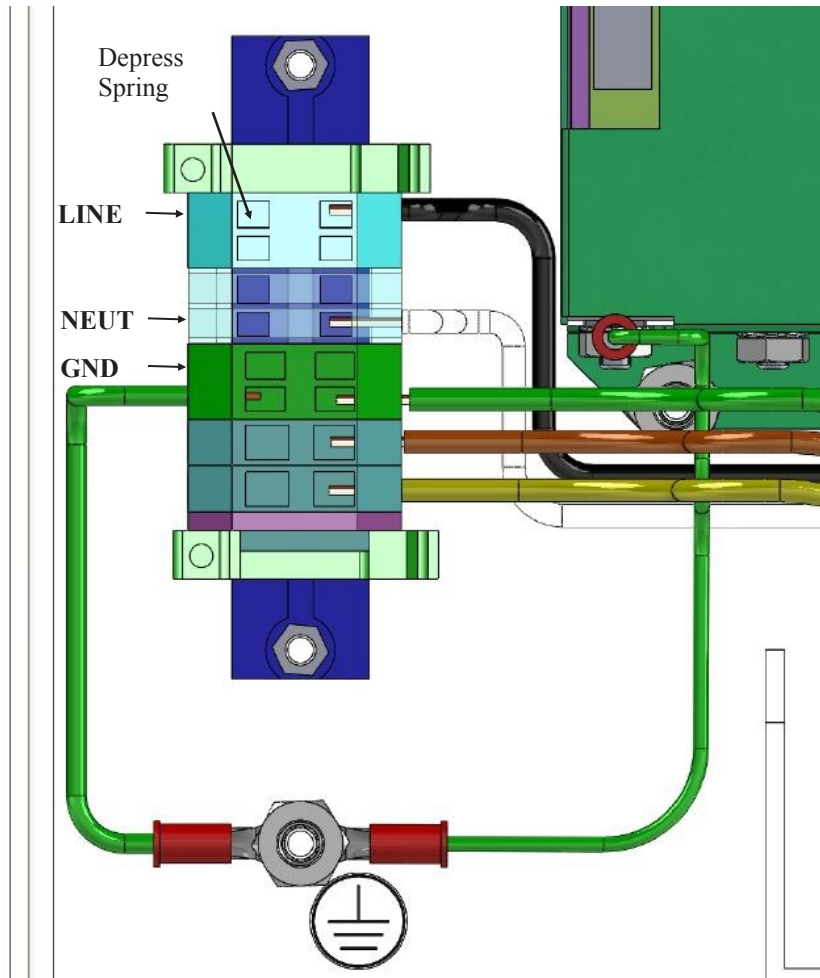



### 3.1 OPLEDW ASSEMBLY CONTINUED

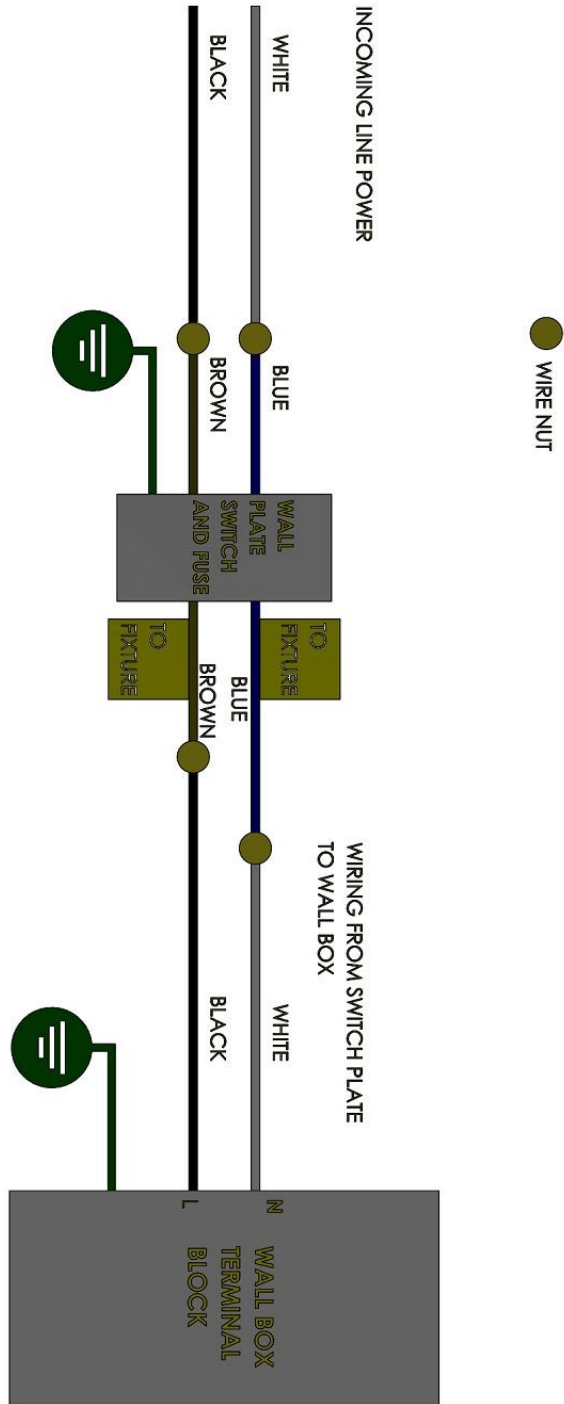

### 3.1 OPLEDW ASSEMBLY CONTINUED

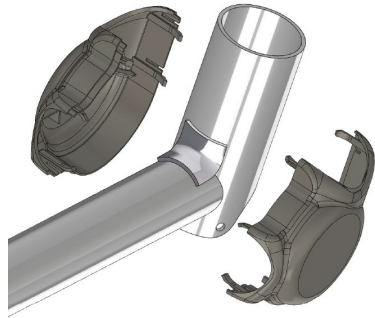

3.1.8  
Gently pull joint covers as shown. Covers are held together by locking clips. Do not break clips.

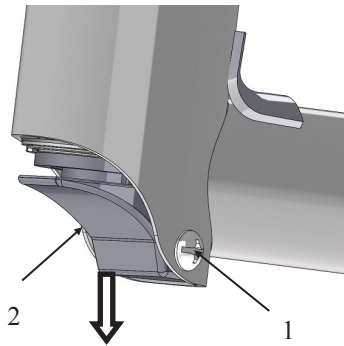

3.1.9  
Remove the two screws (1) and gently pull down on slip ring assembly (2).

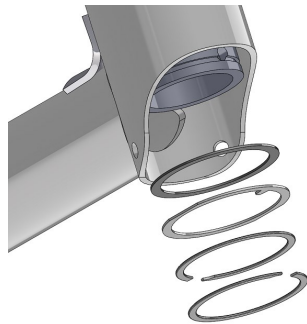

3.1.10  
Align the wall box shaft to the extension arm as shown. Push up on the arm until it is flush against the wall box shaft and can travel no further. This will expose the locking ring groove. Retrieve the locking rings for installation.



3.1.11  
Care must be taken to install the locking rings in this specific order.

### 3.1 OPLEDW ASSEMBLY CONTINUED

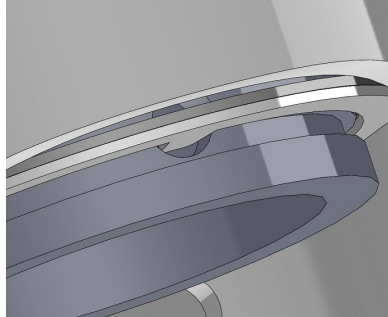

**3.1.12**  
Insert locking ring 1 around the box shaft as shown. Follow by inserting locking ring 2 (with tab) and align tab to the shaft hole as shown. Make sure both locking rings are concentric around the shaft. Locking rings should stay in place if inserted correctly.

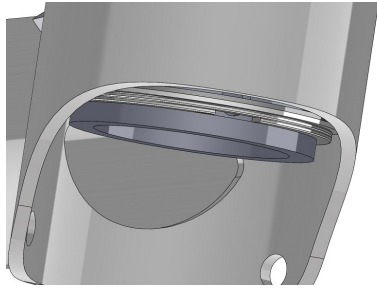

**3.1.13**  
Insert locking ring 3 into the shaft groove. Locking ring 3 should snap in position and be positioned inside the locking ring groove. Follow up and insert locking ring 4 also making sure it is aligned to the groove.

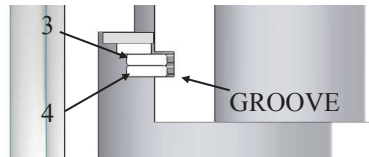

**3.1.14**  
Close up of how the locking rings should align. Make sure locking rings 3 and 4 are aligned and sitting inside the shaft groove. Test by gently pull directly down at the shaft and arm mating location.

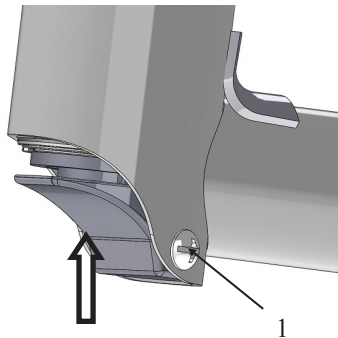

**3.1.15**  
Align the slip ring assembly removed in step 3.1.9 and push into alignment with the mating connection in the wall box shaft. Once in mated, reinstall the two screws (1) to hold the slip ring assembly in place.

### 3.1 OPLEDW ASSEMBLY CONTINUED

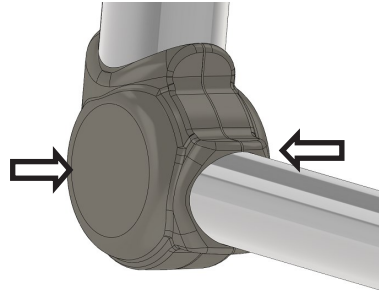

3.1.16  
Reinstall joint covers by gently locking the two pieces together around the joint.

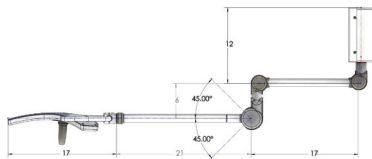

3.1.17  
Once complete with the extension arm to wall box assembly. Follow steps 2.1.25 thru 2.1.36 to install the head and yoke assembly to the extension arm.



3.1.18  
Insert fixture handle to the light head, resistance may be needed behind the head to insert the handle. You will hear a snap when fully engaged. Test by gently pulling on handle away from head.

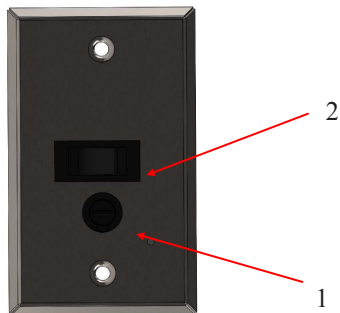

3.1.19  
Finally install the fuse (1) back into the wall switch. Turn on the breaker that supplies line power to the wall switch. Test by pressing the wall switch (2) to the ON position.



#### 4.0 OPLEDSC ASSEMBLY

	<b>WARNING</b>	Fixture must be installed by certified installers. Failure to use a certified installer could potentially result in injury.
---	----------------	---

Prior to start, make sure all components are available for assembly and installation.

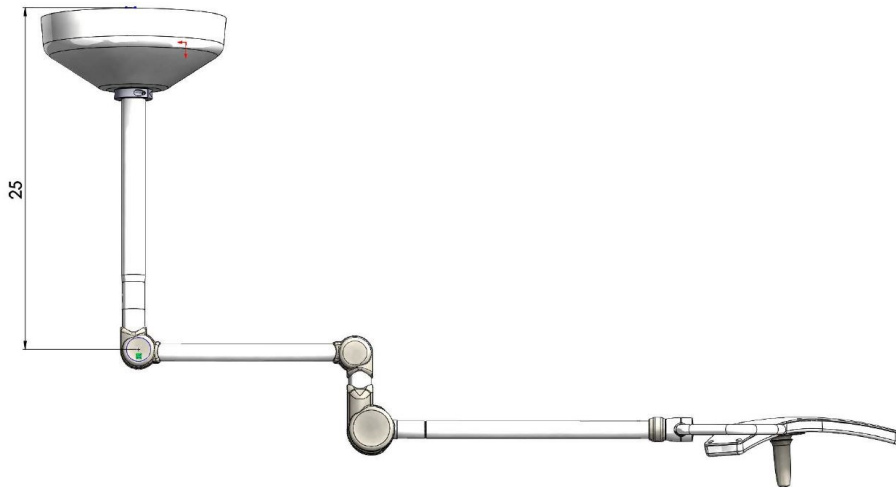
#### Assembled Fixture



Component Picture	Description	Part Number
	Ceiling Mount Power Supply Base Cover	6000312
	OPLED SC Down Tube	6000312

#### 4.0 OPLEDSC ASSEMBLY CONTINUED

Component Picture	Description	Part Number
 <p>A circular metal base plate with a central hole and several smaller holes around the perimeter. A green power supply unit is mounted on top, with red and black wires extending from it. A metal bracket is also attached to the side of the base.</p>	Ceiling Mount Power Supply Base	6000312
 <p>A long, silver-colored metal arm with a spring mechanism. It has a curved end with a circular opening and a threaded end with a cap.</p>	OPLED Extension / Spring Arm	4000288
 <p>A silver-colored metal assembly consisting of a curved yoke and a head. The head has a circular opening and a small protrusion. A screw is shown separately below the assembly.</p>	OPLED Head and Yoke Assembly	6000263
 <p>A black rectangular wall switch plate with a central rectangular cutout. It has two circular holes, one above and one below the cutout, and a small circular hole at the bottom.</p>	OPLED Wall Switch 2A Fuse	6000134-1
 <p>A silver-colored metal clamp with a circular opening and a small protrusion on the side.</p>	Ceiling Cover Clamp to Down Tube	6000312

#### 4.1 OPLEDSC ASSEMBLY CONTINUED

	<b>ELECTRICAL SHOCK</b>	Disconnect all power and remove all fuses prior to assembly.
---	-------------------------	--

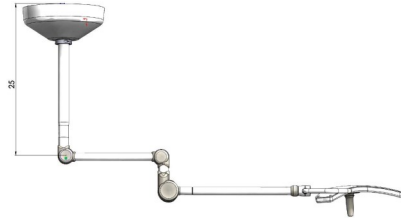

##### 4.1.0

Prepare your room for installation. Make note of the arm lengths and travel. Dimensions for arm length is in section 3.0. The SC arm is the same length as the wall mount arm. Down tube height is provided in section 4.0. It is the responsibility of the installer to consider fixture dimensions prior to mounting. Also consider the location of the wall switch. This switch is mandatory for all W, SC, DC installations.

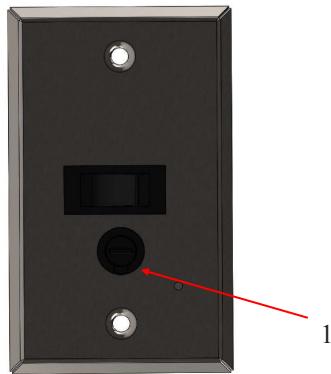

##### 4.1.1

Make sure all electrical power is turned off at the breaker panel prior to start. Start by mounting your wall switch. Remove the fuse (1). This wall switch will fit in standard single gang electrical boxes. It is the responsibility of the installer to mount this wall switch to code. Reference 4.1.2 for wiring connections.

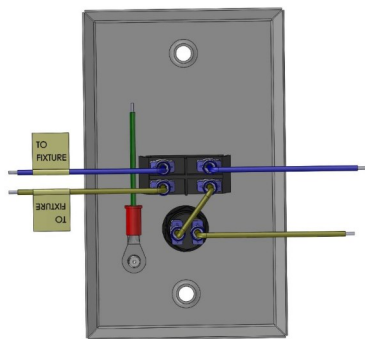

##### 4.1.2

Connect the wires from the ceiling mount to the wall switch. Line side is connected to the brown lead with the label "To Fixture" of the wall switch. Neutral is connected to the blue lead with the label "to Fixture" of the wall switch. Ground on the wall switch is connected to safety ground. The brown (Line) and blue (Neutral) without the label is connected to the building power. Make sure all power is disabled prior to connecting wires.

#### 4.1 OPLEDSC ASSEMBLY CONTINUED

#### 4.1.2 WALL SWITCH WIRING FOR SINGLE CEILING

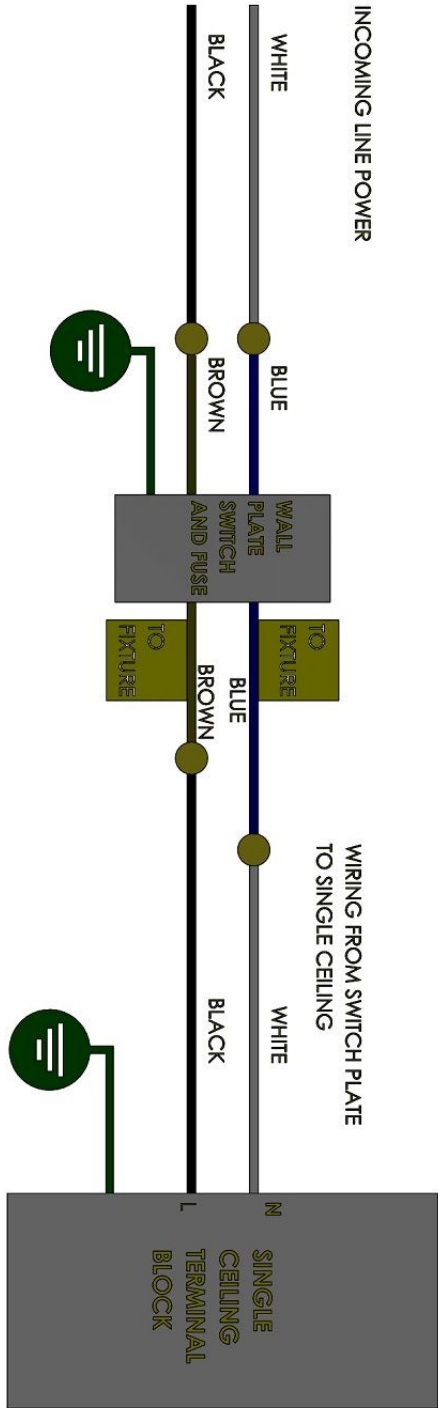



#### 4.1 OPLEDSC ASSEMBLY CONTINUED

	<p><b>ELECTRICAL SHOCK</b></p>	<p>Disconnect all power and remove all fuses prior to assembly. Fixture must be installed by certified installers. Failure to use a certified installer could potentially result in injury.</p>
---	--------------------------------	---

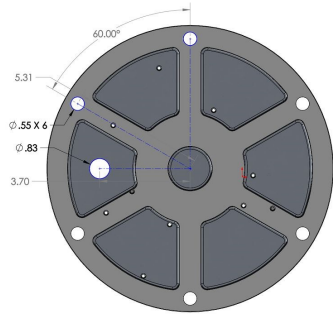

**4.1.7**  
 There are six holes provided for mounting. It is up to the installer to provide the structural support to the fixture. Weights for fixture is provided in Section 8. Make sure ceiling base is level, otherwise arms could drift. It is imperative that solid structural support and proper installation be provided. Ceiling structure should not move when fixture is being rotated or adjusted.

#### INPUT TERMINAL BLOCK

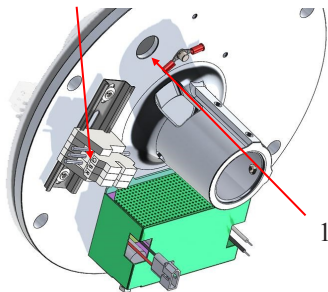

**4.1.8**  
 Run your electrical conduit from the wall switch thru to the back side 0.875" hole provide (1) in the ceiling mount base. This is where the conduit connection must past through the base and secured to the base.

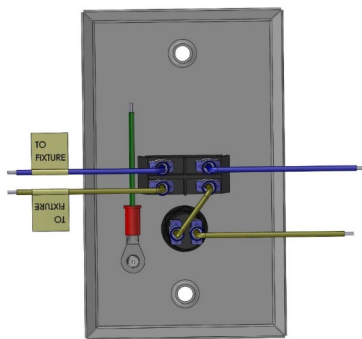

**4.1.9**  
 Follow wall switch wiring to connect incoming wires from wall plate to ceiling base terminal block. Make sure all power is disabled prior to connecting wires.

#### 4.1 OPLEDSC ASSEMBLY CONTINUED

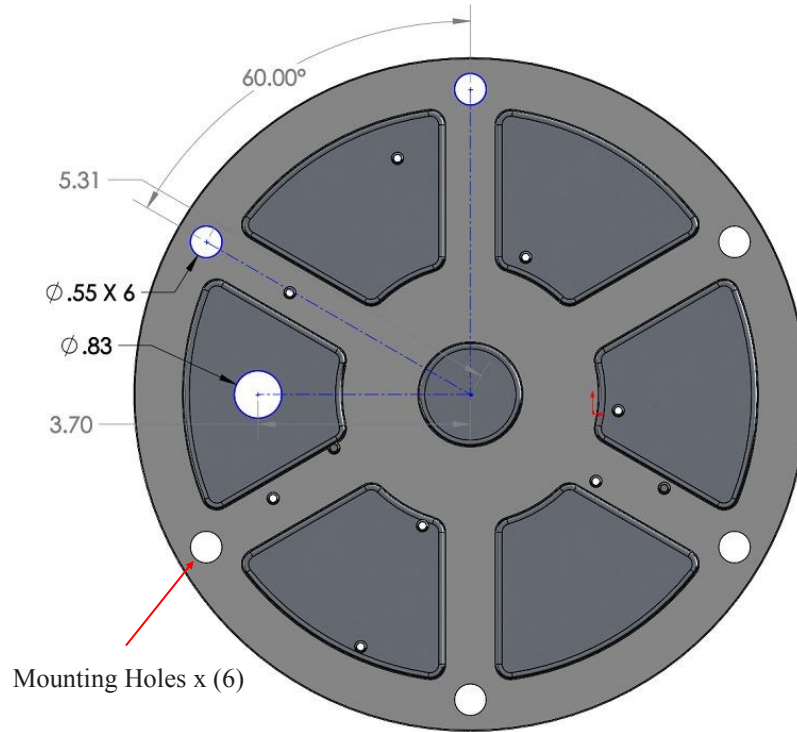

#### 4.1.7 Ceiling base detailed view

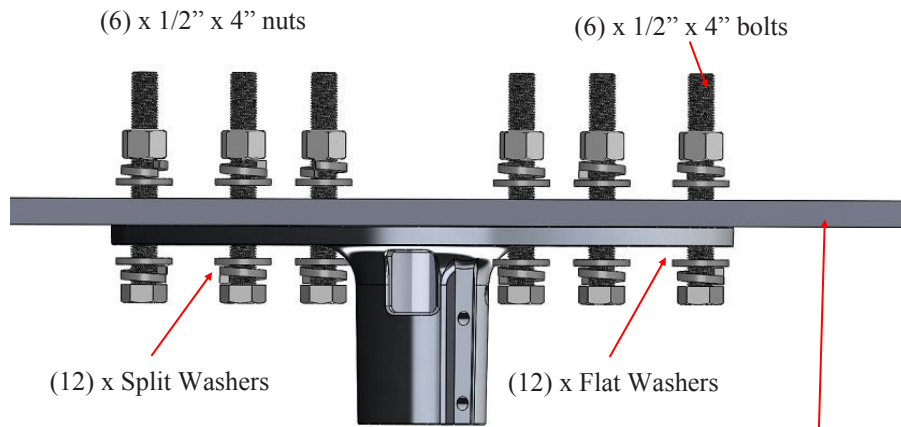

Structural Ceiling—Provided by installer. Picture is only representative, additional beams and mounting members may be required.

#### 4.1 OPLEDSC ASSEMBLY CONTINUED

	<b>ELECTRICAL SHOCK</b>	Disconnect all power and remove all fuses prior to assembly.
---	-------------------------	--

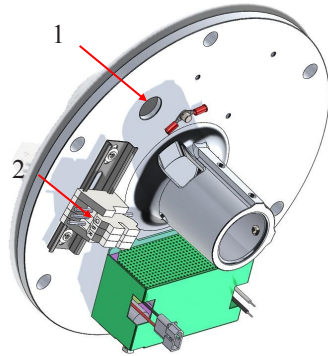

**4.1.10**  
Secure your electrical ground to the GND terminal provided (2). 16-18AWG wire may be used. Depress the spring on the terminal block and insert wire. Gently tug wire to make sure it is securely in place.

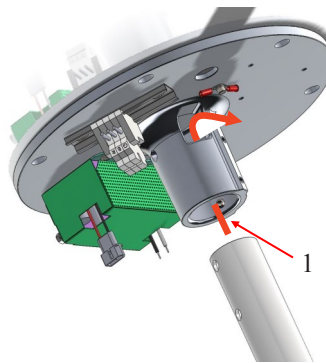

**4.1.11**  
Locate the SC down tube. There is a cable not shown that must be inserted thru the ceiling base down tube mating thru the ceiling base down tube shaft (1). Align the down tube shaft to the ceiling base shaft. While gently pulling cable thru, push up on the down tube into the ceiling base.

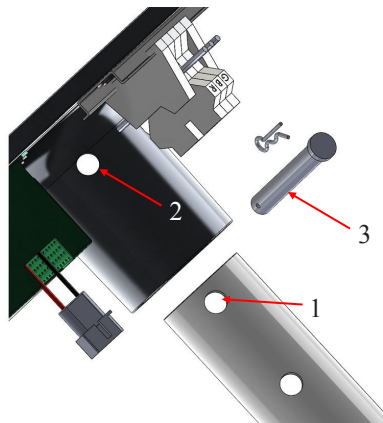

**4.1.12**  
Make sure the down tube holes (1) are aligned to the ceiling base holes (2). The holes need to be concentric to push in pin (3). It is advised to check this pin condition yearly as part of your maintenance program for this fixture.

#### 4.1 OPLEDSC ASSEMBLY CONTINUED

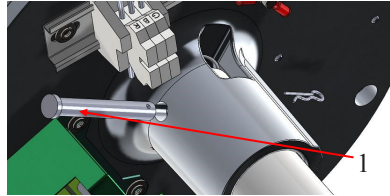

4.1.13  
Insert pin (1) thru the ceiling base and down tube hole. This will require a little patience to do. Make sure the pin is inserted and penetrates both sides of the ceiling and down tube holes.

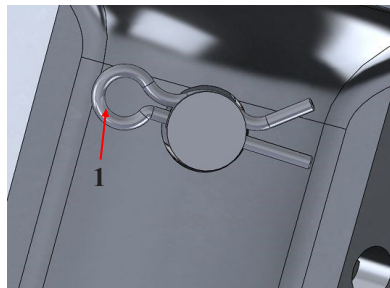

4.1.14  
Once pin penetrates both sides, a hole at the end of the pin is visible. Insert the safety locking clip (1) into the hole and make sure it snaps in place. One side of the pin is straight and the other has a bend. When inserted correctly the bend should be concentric with the pin.

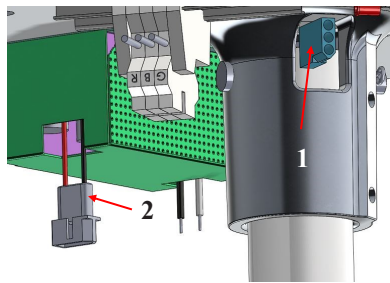

4.1.15  
Connect the cable that is pulled out thru 4.1.11 (1) to the ceiling base power supply (PS) connector (2). There is a third GND position on the PS connector (2) that is already tied to ceiling base GND that is not pictured.

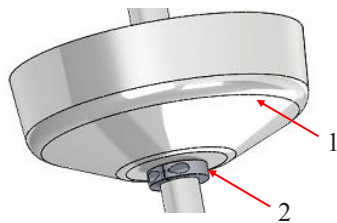

4.1.16  
Locate the ceiling base cover (1) and the Ceiling Cover Clamp to Down Tube (2). Insert the ceiling base cover and connect the GND wire to the Ceiling base GND. There are two bolts holding the clamp (2) together. Loosen those two bolts and slide clamp onto the single ceiling post as shown.



4.1.17  
Ceiling Cover Clamp to Down Tube Assembly

#### 4.1 OPLEDSC ASSEMBLY CONTINUED



4.1.18  
Push up on the ceiling cover clamp against the ceiling cover until ceiling cover is flush with ceiling. Make sure all wires are neatly inside the ceiling cover and none are pinched. Once cover is flush, fasten the socket cap screws in the clamp to secure it in place. Your fixture should look like the picture on the left at this point. Add lube to stem (1).

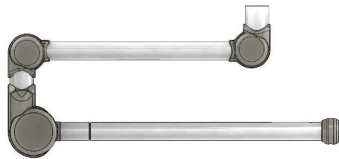

4.1.19  
Locate the extension/spring arm assembly.

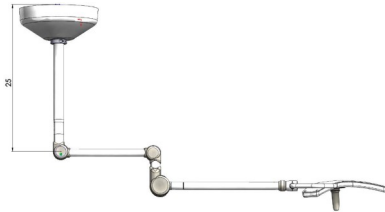

4.1.20  
Follow steps 3.1.8 thru 3.1.16 to install the extension arm to the down tube.

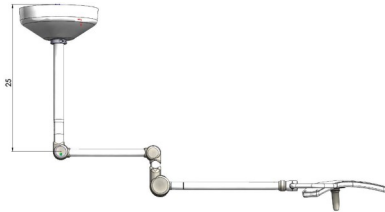

4.1.21  
Once complete with the extension arm to down tube assembly, follow steps 2.1.25 thru 2.1.36 to install the head and yoke assembly to the extension arm.



4.1.22  
Insert fixture handle to the light head, resistance may be needed behind the head to insert the handle. You will hear a snap when fully engaged. Test by gently pulling on handle away from head.

#### 4.1 OPLEDSC ASSEMBLY CONTINUED

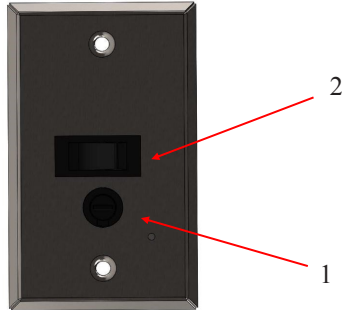

4.1.23  
When completed, your fixture should look like the picture at the beginning of section 4.0. Finally install the fuse (1) back into the wall switch. Turn on the breaker that supplies line power to the wall switch. Test by pressing the wall switch (2) to the ON position.

#### OPLEDSC ASSEMBLY COMPLETE

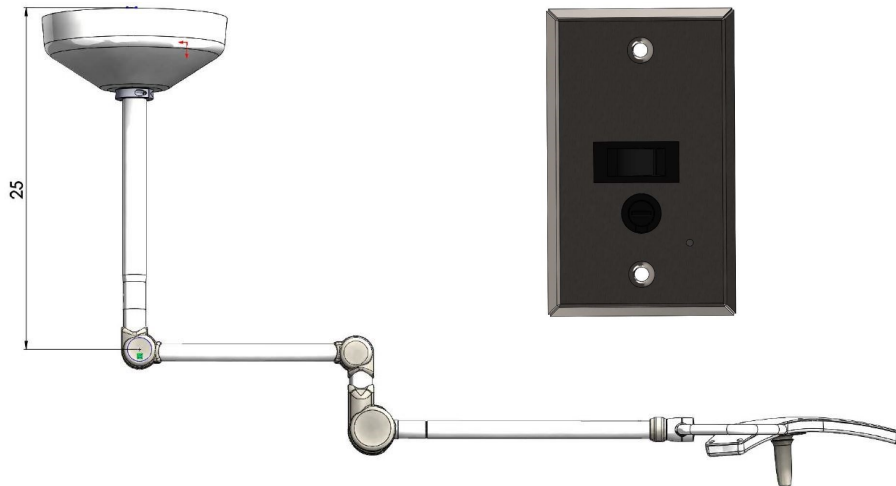



## 5.0 OPLEDDC ASSEMBLY

	<b>WARNING</b>	Fixture must be installed by certified installers. Failure to use a certified installer could potentially result in injury.
---	----------------	---

Prior to start, make sure all components are available for assembly and installation.

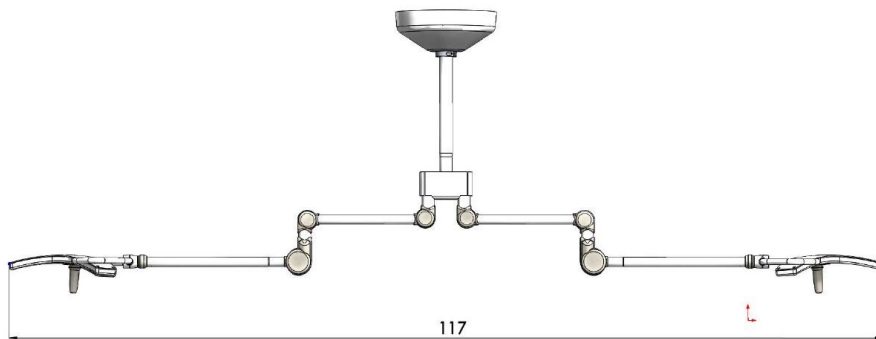
### Assembled Fixture



Component Picture	Description	Part Number
	Ceiling Mount Power Supply Base Cover	6000313
	OPLEDDC Down Tube and Splitter	6000313

### 5.0 OPLEDDC ASSEMBLY CONTINUED

Component Picture	Description	Part Number
	Ceiling Mount Power Supply Base	6000313
	(2x) OPLED Extension / Spring Arm	4000288
	(2x) OPLED Head and Yoke Assembly	6000263
	OPLED Wall Switch 3A Fuse	6000134
	Ceiling Cover Clamp to Down Tube	6000313



## 5.1 OPLEDDC ASSEMBLY CONTINUED

	<b>ELECTRICAL SHOCK</b>	Disconnect all power and remove all fuses prior to assembly.
---	-------------------------	--

### 5.1.0

Prepare your room for installation. Make note of the arm lengths and travel. Dimensions for arm length is in section 5.0. Down tube height is provided in section 4.0. It is the responsibility of the installer to consider fixture dimensions prior to mounting. Also consider the location of the wall switch. This switch is mandatory for all W, SC, DC installations.

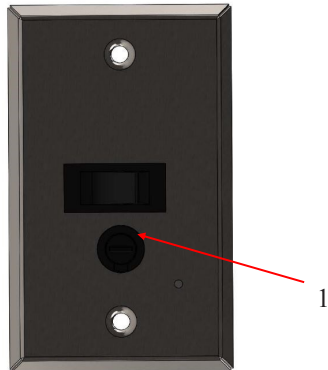
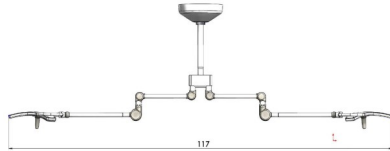

### 5.1.1

Make sure all electrical power is turned off at the breaker panel prior to start. Start by mounting your wall switch. Remove the fuse (1). This wall switch will fit in standard single gang electrical boxes. It is the responsibility of the installer to mount this wall switch to code. Reference 3.1.7 for wiring connections.

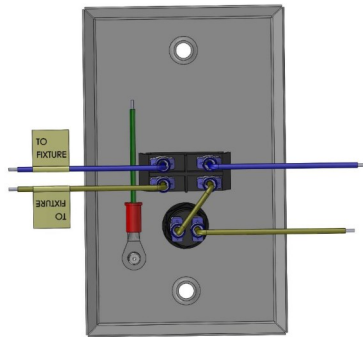

### 5.1.2

Connect the wires from the double ceiling mount to the wall switch. Line side is connected to the brown lead with the label "To Fixture" of the wall switch. Neutral is connected to the blue lead with the label "to Fixture" of the wall switch. Ground on the wall switch is connected to safety ground. The brown (Line) and blue (Neutral) without the label is connected to the building power. Make sure all power is disabled prior to connecting wires.

5.1 OPLEDDC ASSEMBLY CONTINUED

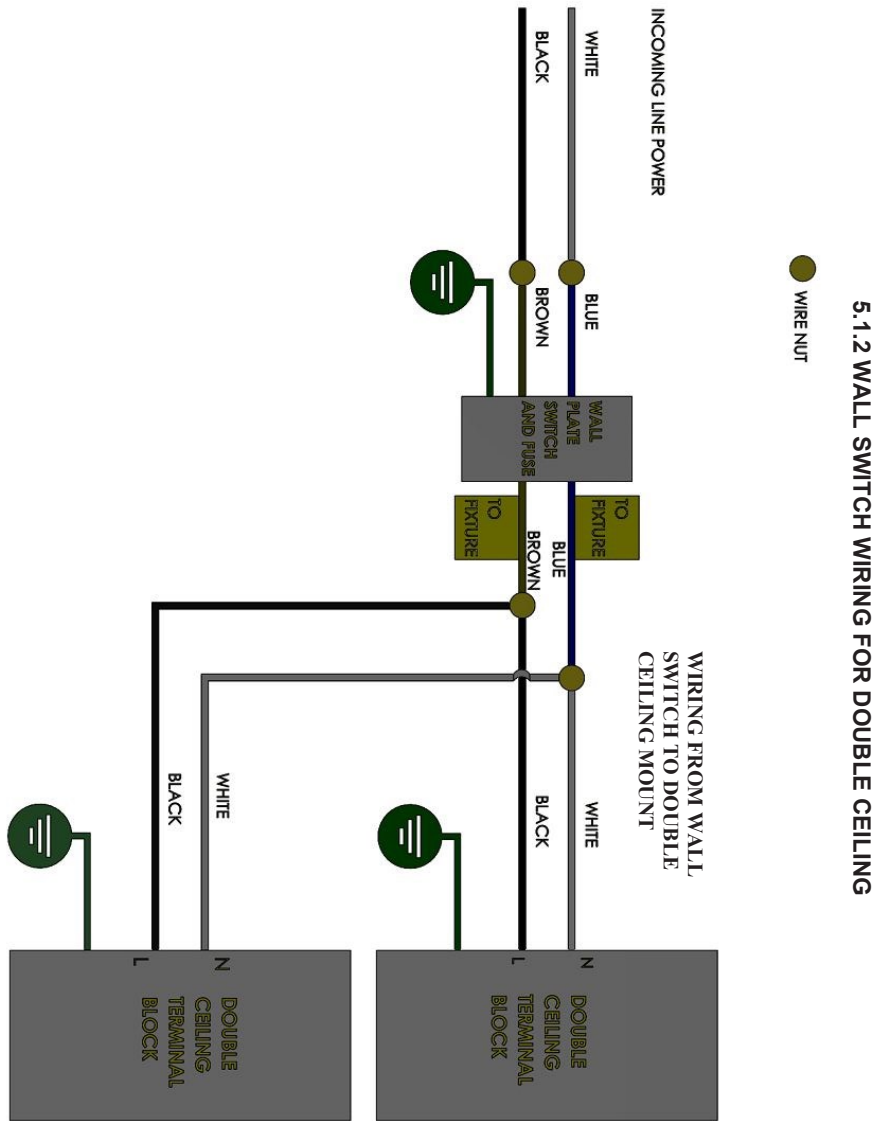

## 5.1 OPLEDDC ASSEMBLY CONTINUED



### ELECTRICAL SHOCK

Disconnect all power and remove all fuses prior to assembly. Fixture must be installed by certified installers. Failure to use a certified installer could potentially result in injury.

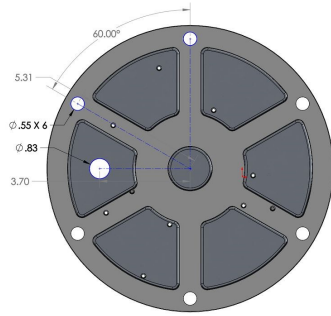

#### 5.1.7

There are six holes provided for mounting. It is up to the installer to provide the structural support to the fixture. Weights for fixture is provided in Section 8. Make sure ceiling base is level, otherwise arms could drift. It is imperative that solid structural support and proper installation be provided. Ceiling structure should not move when fixture is being rotated or adjusted.

### INPUT TERMINAL BLOCKS

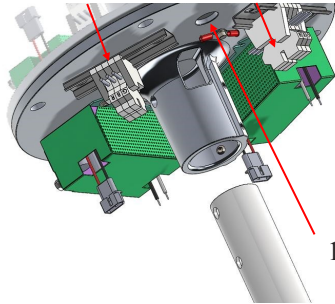

#### 5.1.8

Run your electrical conduit from the wall switch thru to the back side 0.875" hole provide (1) in the ceiling mount base. This is where the conduit connection must past through the base and secured to the base.

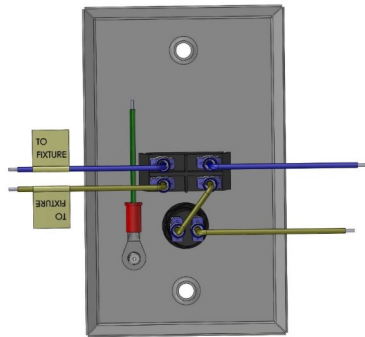

#### 5.1.9

Follow wall switch wiring to connect incoming wires from wall plate to ceiling base terminal block. Make sure all power is disabled prior to connecting wires.

## 5.1 OPLEDDC ASSEMBLY CONTINUED

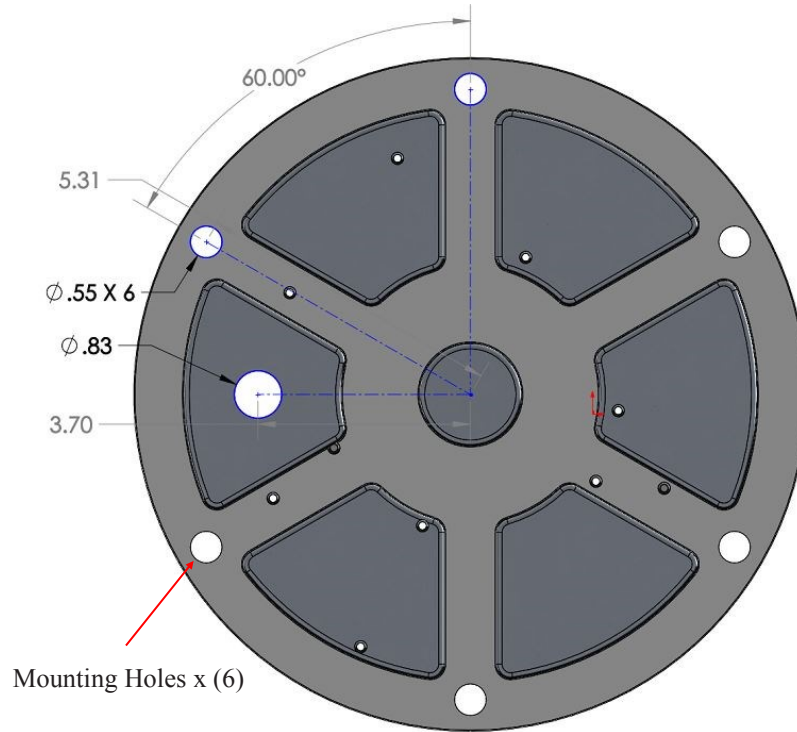

### 5.1.7 Ceiling base detailed view

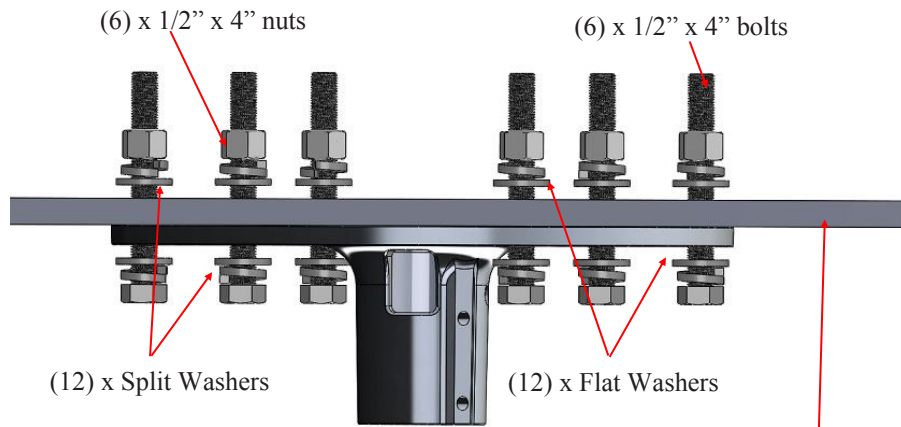

Structural Ceiling—Provided by installer. Picture is only representative, additional beams and mounting members may be required. Ceiling should not sway or move when adjusting fixture.

## 5.1 OPLEDDC ASSEMBLY CONTINUED



### ELECTRICAL SHOCK

Disconnect all power and remove all fuses prior to assembly.

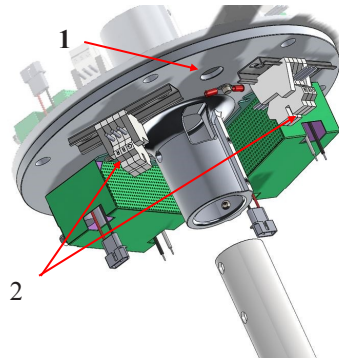

#### 5.1.10

Run your electrical conduit from the wall switch thru to the back side 0.875" hole provide (1) in the ceiling mount base. Secure your electrical ground to the GND terminal provided (2). 16-18AWG wire may be used. Depress the spring on the terminal block and insert wire. Gently tug wire to make sure it is securely in place.

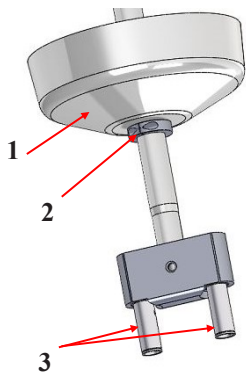

#### 5.1.11

Locate the DC down tube. Insert the ceiling cover (1) and clamps (2) as shown prior to inserting into ceiling base. You will not be able to get the ceiling cover on if you skip this step. Add lube to both stem (3).

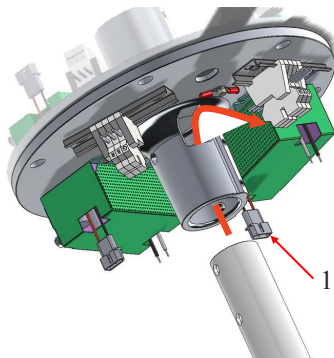

#### 5.1.12

There are two cables not shown that must be inserted thru the ceiling base down tube mating shaft (1). Align the down tube shaft to the ceiling base shaft. While gently pulling cable thru, push up on the down tube into the ceiling base.

## 5.1 OPLEDDC ASSEMBLY CONTINUED

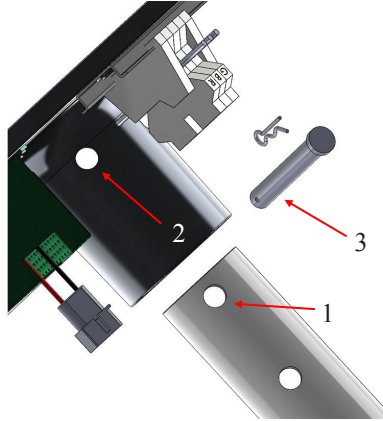

5.1.13  
Make sure the down tube holes (1) are aligned to the ceiling base holes (2). The holes need to be concentric to push in pin (3).

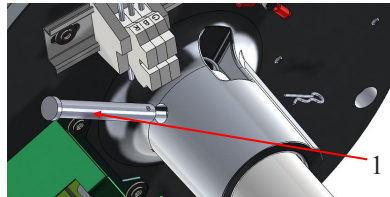

5.1.14  
Insert pin (1) thru the ceiling base and down tube hole. This will require a little patience to do. Make sure the pin is inserted and penetrates both sides of the ceiling and down tube holes.

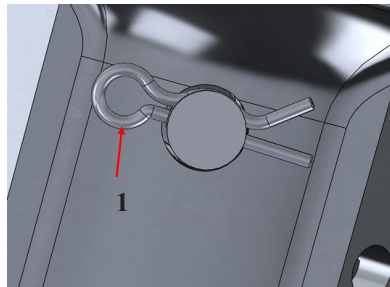

5.1.15  
Once pin penetrates both sides, a hole at the end of the pin should be visible. Insert the safety locking clip (1) into the hole and make sure it snaps in place. One side of the pin is straight and the other has a bend. When inserted correctly the bend should be concentric with the pin.

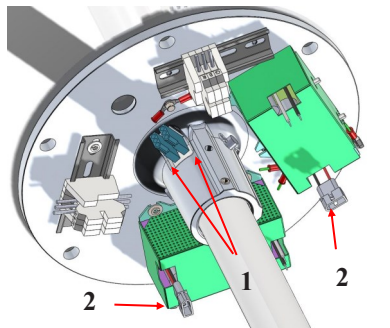

5.1.16  
Connect the two cables that are pulled out thru 5.1.11 (1) to the ceiling base power supply (PS) connector (2). There is a third GND position on the PS connector (2) that is already tied to ceiling base GND that is not pictured. The cables should have a "Arm 1" or "Arm 2" label that should be connected to Power Supply 1 or Power Supply 2.

## 5.1 OPLEDDC ASSEMBLY CONTINUED



**ELECTRICAL  
SHOCK**

Disconnect all power and remove all fuses prior to assembly.

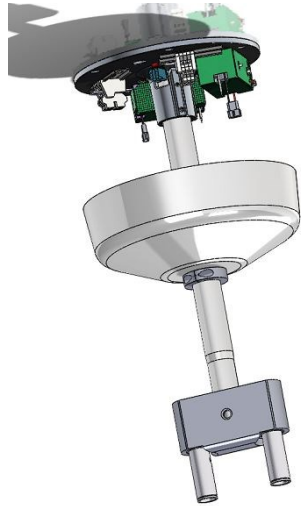

### 5.1.17

At this stage, your fixture assembly should now look like this. Ceiling cover should be on down tube. Fixture should be plumb and level with ceiling.

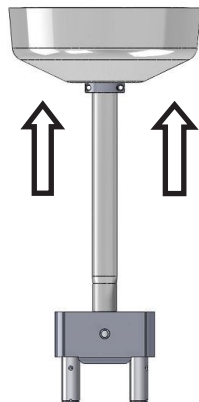

### 5.1.18

Push up on the ceiling cover clamp against the ceiling cover until ceiling cover is flush with ceiling. Make sure all wires are neatly inside the ceiling cover and none are pinched. Once cover is flush, fasten the socket cap screws in the clamp to secure it in place. Your fixture should look like the picture on the left at this point.

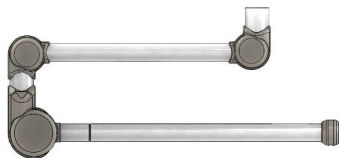

### 5.1.19

Locate extension arms (2).

## 5.1 OPLEDDC ASSEMBLY CONTINUED

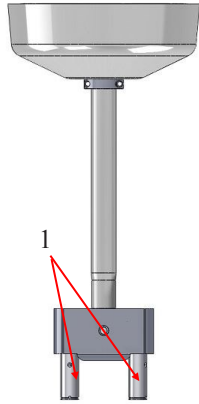

5.1.20  
Follow steps 3.1.8 thru 3.1.16 to install both extension arms to the DC down tube splitter shafts (1) .



5.1.21  
Once complete with the extension arm to down tube assembly. Follow steps 2.1.25 thru 2.1.36 to install the head and yoke assembly to both extension arms.



5.1.22  
Insert fixture handle to the light head, resistance may be needed behind the head to insert the handle. You will hear a snap when fully engaged. Test by gently pulling on handle away from head.

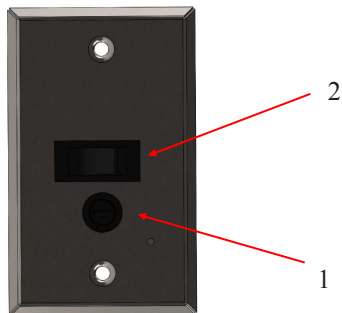

5.1.23  
When completed, your fixture should look like the picture at the beginning of section 5.0. Finally install the 3A fuse (1) back into the wall switch. Turn on the breaker that supplies line power to the wall switch. Test by pressing the wall switch (2) to the ON position.



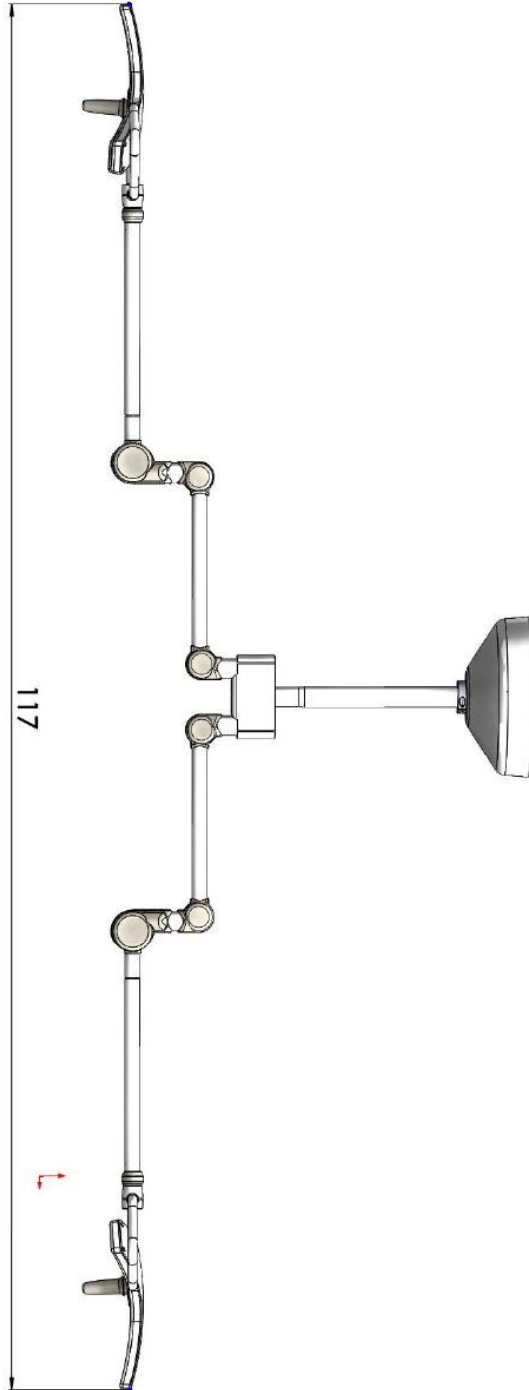

5.1 OPLEDSC ASSEMBLY CONTINUED



5.1.23 COMPLETE DOUBLE CEILING FIXTURE

## 6.0 ADDITIONAL NOTES

 	WARNING  NOTE	<p>To prevent sway and provide proper support to the light, the ceiling mount must be attached to a structurally sound ceiling, which is able to support 400 lbs. Most ceilings will require adequate reinforcing to hold the light. The installing contractor is responsible for providing this reinforcement to suit the individual requirements of each installation. Sway braces (e.g., made of angle iron) are recommended when there are more than 12" between the structural and finished ceilings. The proper height of the light should be set by the end user. Typically the arms are installed 6-ft 6-in (~78") above the floor. This allows the light heads to be adjusted within a vertical range of ~30".</p>
--	---------------------	---

## 7.0 TROUBLESHOOTING GUIDE

	<b>WARNING</b>	Troubleshooting shall be performed by electricians or certified installers ONLY! Do not attempt to troubleshoot without the proper training and knowledge.
Symptom	Probable Cause	Corrective Action
One LED module does not light.	Intermittent cable/contact connection  LED module failed.	Reseat cables and connectors  Switch cable from a working module to the non-working module and vice versa. If symptom follows cable, replace cable, if not replace malfunctioning LED module. See LED module replacement instructions.
All three modules do not light	Not plugged in  Switch not on ( ○ ).  Fuses not present or failed  Transient voltage spikes i.e. lightning strike  Short or open circuit in power supply.  Switch failure (or defective).	Plug into a suitable Hospital-grade outlet.  Turn switch on (   ).  Have a qualified electrician check all fuses. Replace with new fuse(s).  Check fuses  Have a qualified electrician check input and output of power supply using appropriate tools  Check switch continuity in on/off states
Module (s) is/are dim.	Weak power supply (defective).	Check output voltage at power supply
Arm moves up or down 1" or more after position set.	Arm tension may not be set correctly.	Spring arm tension is set at the factory. If arms are not holding position and drift more than one inch, contact factory for replacement part.
Arm drifts left or right.	Unlevel installation.	Check that installation is "plumb". If not, contact the installer for support.



## 7.0 TROUBLESHOOTING GUIDE CONTINUED

	<b>WARNING</b>	Troubleshooting shall be performed by certified installers ONLY! Do not attempt to troubleshoot without the proper training and knowledge.
---	----------------	--

### Fuse Replacement

**Ceiling and Wall Mounts**—Disconnect power to the lamp circuit at the main breaker before replacing fuses. Fuse is located at the wall switch.

**Floor Mount**—Unplug the cord from the wall and remove it from the floor stand. Fuse are attached next to the power inlet with a snap fit for easy removal and replacement.

	<b>WARNING</b>	Electrical Shock Warning! Make sure all power to fixtures are disconnected before performing any maintenance work on fixture.
	<b>HOT SURFACE</b>	Surfaces on the light head can get hot. Use extra caution when coming into contact with light head.

### LED Module Replacement

Before doing any maintenance inside the light head, allow LED modules to cool. If the light has been operating for 10 minutes or more, allow at least 30 minutes for cooling.

The top cover is attached to the housing with nine socket cap screws. Separate the top cover from the bottom by lifting it away from the housing. Be careful not to pull wires (1) loose during removal of the top cover.

Remove the faulty LED Module by disconnecting the lead wires (black and red) from the terminal block in the center. Remove the red and black wire harness (1) from the module by carefully pulling the harness away from the module. Remove the two screws (2) on the module assembly. The assembly can now be removed.

Install the new LED module by connecting the lead wires (black and red) to the appropriate terminal block. Secure the module to the housing with the two screws. Do not over tightened the screws. (Max 2.5 in-lbs)

Carefully place wires back into housing and replace lid making sure wires are not pinched in

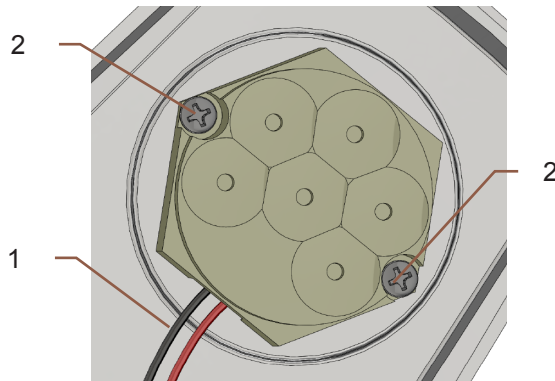

## 8.0 TECHNICAL DATA<sup>1</sup>

Type of Data	
<b><u>Classifications</u></b>	
Type of Protection Against Electric Shock	Class I
FDA Classification	FDA Class I, ExaminationLight
CISPR II Classification	Group 1, Class A
Allowable Earth Leakage Current	Does not exceed 500 $\mu$ A
Allowable Touch Leakage Current	Does not exceed 100 $\mu$ A
Reliability of Earth Protection	Does not exceed 0.1 ohm
Mode of Operation	Continuous
Protection Against Explosion Hazards	Not to be used in the presence of flammable anesthetics
Protection Against Hazardous Parts and Ingress of Liquids	IP20
Degree of Mobility	Wall/Ceiling versions: Permanently installed. Floor stand version: mobile.
Approvals	AAMI ES60601-1 3rd edition; IEC 60601-2-41; IEC60601-1-2; CSA 22 No. 601.1 M-90
Expected Life	5 years
Standards	Meets the requirements for surgical task lighting in ANSI/IESNA RP-29-06, Lighting for Hospitals and Health Care Facilities

## 8.0 TECHNICAL DATA CONTINUED

<b>Electrical</b>	
Supply Connections	120V, 50/60Hz
Power Consumption	42W (Single Ceiling, Wall, Floor), 84W (Double Ceiling) (typ)
LED Modules	24VDC, 12W each
Fusing	<p><b>Floor:</b> (2 fuses) T 2 A L, 250V, 5x20mm</p> <p><b>Wall, Single Ceiling:</b> (1 fuse) T 2 A L, 250V, 5x20 mm</p> <p><b>Double Ceiling:</b> (1 fuse) T 3 A L, 250V, 5x20 mm</p> <p>The T indicates Time delay (i.e. slow blow fuses). There are 2 fuses in the floor stand. There is 1 fuse in the wall, single ceiling and double ceiling mounting options.</p>
Power Cord (Floor Stand & Wall Version)	8 ft. (2.44m), NEMA 5-15, hospital-grade plug
EMC	IEC60601-1-2
	<p style="text-align: center;"><b>NOTE</b></p> <p>This device has been tested to IEC60601-1-2 for Electromagnetic Compliance. The device is not expected to interfere with equipment that may be operating in the same environment. If you are experiencing EMC issues, please contact your technical support personnel to identify source of interference. If there are additional concerns or questions regarding EMC please contact Philips Burton for additional help.</p>
<b>Transport and Storage Conditions</b>	
Ambient Temperature	0°-70° C (32°-158° F)
Relative Humidity	10 - 100% (no condensation)
Atmospheric Pressure	500hPa - 1060 hPa
<b>Operation Conditions</b>	
Ambient Temperature	10°- 40°C (50°-104°F)
Relative Humidity	30 - 75%
Atmospheric Pressure	700hPa - 1060 hPa

## 8.0 TECHNICAL DATA CONTINUED

<b>Weights and Dimensions (Weights and Dimensions are rounded)</b>	
Spring Arm (light head to extension arm/upright)	4 lbs., 22 in. (55 cm)
Extension arm (down tube to Spring Arm)	3 lbs., 16.5 in. (42 cm)
Single Ceiling Flange with Power Supply and Cover	7 lbs., 12 in (30 cm)
Double Ceiling Flange with Power Supply and Cover	8 lbs., 12 in (30 cm)
Ceiling mount down tube length (custom lengths available)	12 in. (30 cm) / 20 in. (50 cm) / 28 in. (70 cm) / 35 in. (90 cm)
Single Ceiling Down Tube	7 lbs., 20 in (50 cm)
Double Ceiling Down Tube with Splitter	11 lbs., 20 in (50 cm)
Floor stand and upright height (from base)	28 lbs., 5 ft. (1.52 m)
Light Head	6 lbs., 16.5 x 16.5 x 4.5 in
Wall Mount Box	13 lbs, 10.2 x 4.1 x 11.96 in

<b>Optical Performance</b>	
Central Illumination at 24" (0.61 m), Ec	90k Lux
Central Illumination at 1m (39.4"), Ec	15.7k Lux
Total Irradiance, Ee	304.2 W/m <sup>2</sup>
Ultraviolet Radiation	< 0.034 W/m <sup>2</sup>
Color temperature	3800° K
CRI (Color Rendering Index)	96

<sup>2</sup>The optical data are nominal values (unless specified otherwise) based on measurements done according to the IEC 60601-2-41 standards. Also, the performance of individual LED modules has a natural variance due to their manufacturing process. Do not substitute. Use only Philips Burton supplied replacement modules. Failure to do so will affect performance and invalidate the warranty status.

## 8.0 TECHNICAL DATA CONTINUED

<b>Ecological Impact</b>	<i>Philips Burton cares about the ecological environment, and in the design and manufacturing of our lights we strive to minimize the ecological impact.</i>
<b>Materials</b>	RoHS compliant materials are used in the production of the lights.
<b>Plastic</b>	The plastic parts are made from an ECO-compliant grade of plastics. This means that no brominated or chlorinated substances are used in the production of the raw material.
<b>Recycling</b>	Most parts of this light can be recycled.
<b>Disposal</b>	To reduce environmental and health impact, dispose of the product through the proper disposal and recycling authorities in your area.



## 9.0 WARRANTY

### Warranty

Mechanical components of Philips Burton's products are warranted to provide the original purchaser five (5) years of free service from defects in material and workmanship. The warranty does not cover the following items: handles, fuses, and consumables.

#### Conditions:

1. This warranty will be granted only when the original invoice or sales receipt is presented together with the product. Philips Burton reserves the right to refuse free-of-charge warranty service if the above documentation cannot be presented, or if the information contained is incomplete or illegible.
2. This warranty will not apply if the serial or lot number on the product has been altered, damaged, removed or made illegible in any way.
3. This warranty does not cover damage or destruction caused by any reason, including but not limited to neglect, deferred maintenance or improper repairs, or any alterations, adaptations or adjustments made to the product to conform to the national or local technical/safety standards in force in any country other than the ones for which the product was originally designed and manufactured.
4. Products for service under warranty must be either returned to the location instructed by your authorized Philips Burton representative or made available to the authorized Philips Burton field personnel, where they will be replaced or repaired free of charge.
5. This warranty does not cover the following:
  - Failure to follow installation instructions.
  - Periodic maintenance and repair or replacement of parts due to normal wear and tear.
  - Any adaptation or change to upgrade the product from its normal purpose without the written consent of Philips Burton.
  - Abuse or misuse of the product.
  - Repair performed by non-authorized or non-certified personnel.
  - Accidents, lightning, water, fire, improper ventilation or any cause beyond the control of Philips Burton.
  - Defects of any equipment system or fixtures into which the product is incorporated, including installation and modification.
6. This warranty does not affect the customer's statutory rights under applicable state or national laws in force, or the customer's rights against the dealer arising from its sales/purchase contract.

This product was manufactured and assembled in the U.S.A. by:

**Philips Burton**

11500 Melrose Avenue  
Franklin Park, IL 60131  
U.S.A.

Tel.: (800) 444-9909

Fax: (800) 765-1770

Web: [www.burtonmedical.com](http://www.burtonmedical.com)

This page intentionally left blank.

